

ELECTRONIC THEODOLITES

Nivel System

DT-2, DT-5

Manual



Measuring solutions
for construction.

www.nivelsystem.com

Precautions

1. Avoid heavy shock

For long-distance transportation, pay attention to external package and shock proof.

2. Setting and moving

When placing the instrument on the tripod head, hold the instrument and rotate the tripod screw until it is fixed securely on top of the tripod head. Repeat the above mentioned procedure for removing the instrument from tripod head. If the instrument must be carried with tripod attached, never carry it horizontally over the shoulder, always keep it in vertical direction when carried. The instrument must be kept in container for long-distance transportation.

3. Keep it clean

Clean dust of the instrument surface with cotton wool or small brush after using the instrument. Dry the instrument on time after exposed in the rain. Make sure not to use chemicals to clean battery case and plastic parts. If necessary, damp soft cloth is permissible. High absorbent cotton and lens-cleaning paper are used for exposed optics. Never use handkerchief and clothes.

4. Avoid the long-time irradiation

Never leave the instrument in extreme heat longer than necessary. It could adversely affect its performance.

5. Check the battery

Be sure to check the battery for voltage level before using the instrument.

6. Notice

Store the instrument in a place with good air circulation and low humidity. Temperature is kept under 45°. Often change the drier in the instrument container.

Content

| | | |
|-----------|--|-----------|
| 1 | Application | 5 |
| 2 | Nomenclature | 6 |
| 3 | Display and display mark | 7 |
| 4 | Operating keyboard and operating key | 8 |
| 5 | Preparative before measurement | 9 |
| 5.1 | Leveling the instrument | 9 |
| 5.2 | Power switch on | 11 |
| 5.3 | Battery power display | 11 |
| 5.4 | Change the battery | 11 |
| 6 | Angle measurement | 12 |
| 6.1 | Measuring a HA_R and vertical angle | 12 |
| 6.2 | Switching horizontal angle HA_R / HA_L | 13 |
| 6.3 | Setting a horizontal angle | 14 |
| 6.4 | Repetition angle measurement | 14 |
| 6.5 | Measuring a percent of grade (Slope measurement) | 17 |
| 7 | Distance measurement | 18 |
| 7.1 | Use with the range finder (EDM) | 18 |
| 7.2 | Join with the EDM | 18 |
| 7.3 | Distance measuring | 18 |
| 8 | Recording and outputting data | 20 |
| 8.1 | Communication interface | 20 |
| 8.2 | Recording measurement data | 20 |
| 9 | Memory mode | 21 |
| 10 | Function setting | 22 |
| 10.1 | Function setting | 22 |
| 10.2 | Function setting method | 22 |
| 10.3 | Time setting | 24 |

| | | |
|-----------|--|-----------|
| 11 | Vertical angle 0 error and collimation error and tilt angle compensator 0 error | 25 |
| 12 | Other function | 26 |
| 12.1 | Measuring distance | 26 |
| 12.2 | Tilt correction function | 27 |
| 12.3 | Illuminate and the timing close | 27 |
| 13 | Check and adjustment | 29 |
| 13.1 | Check and adjust plate level | 29 |
| 13.2 | Check and adjust circular level | 29 |
| 13.3 | Check and adjust vertical cross-hair | 29 |
| 13.4 | Calibration of the E-Bubble | 31 |
| 13.5 | Collimation of the instrument sight line | 32 |
| 13.6 | Check and adjust optical plummet | 34 |
| 13.7 | Check and adjust Laser plummet | 35 |
| 13.8 | Check and adjust Laser pointer | 35 |
| 14 | Tribrach | 36 |
| 15 | Error display | 37 |
| 16 | Specifications | 38 |
| 17 | Standard Accessories | 39 |

1. Application

Our digit theodolite adopts absolute coding digit angle measurement system. The resolution of horizontal angle reading and vertical angle reading is 1" , 5" ,10" (0.2mgon、1mgon 2mgon). The angle precision is 2" , 5" ,10" (0.5mgon 、 1mgon, 2mgon).Meanwhile microcomputer techniques adopted in the instrument realizes automatic calculation, storage, and display. The instrument can display the readings of horizontal angle and vertical angle simultaneously. Joined with the range finder and PDA, it can be made up of a combined Total Station, performing the function of measuring, displaying and recording the angle, distance and coordinate data.

Our electronic theodolite can be used for the control surveying, mine, railway, and irrigation etc projects surveys. Still capable of topographic surveys and general projects surveys.

2. Nomenclature

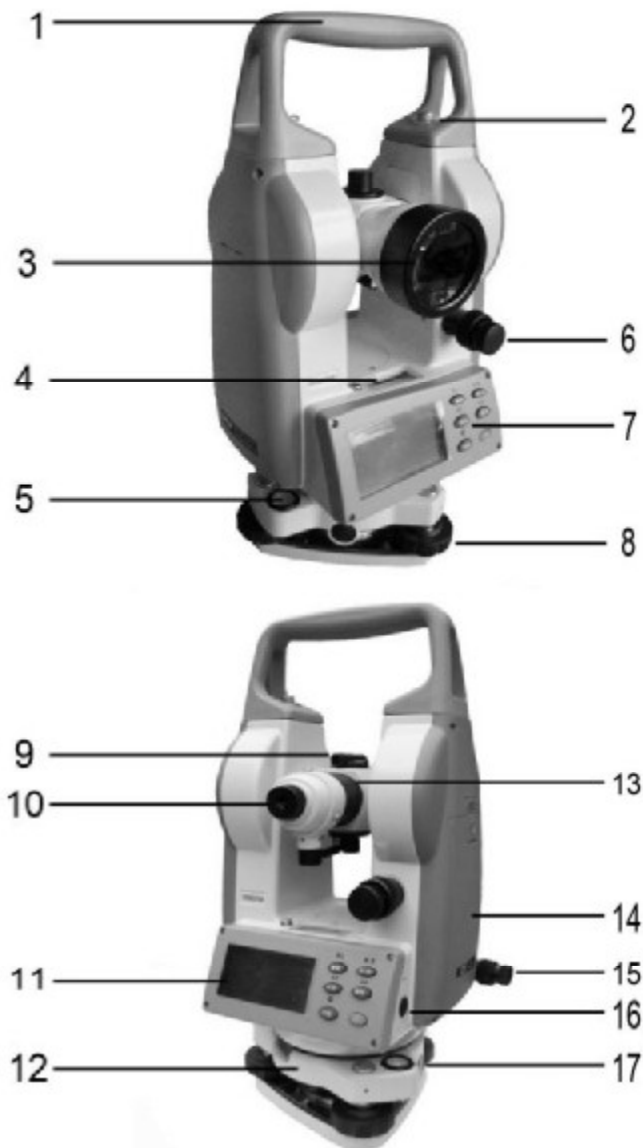

(1) Carrying handle (2) Handle screw (3) Objective lens (4) Plate level (5) Circular bubble (6) Vertical tangent screw and motion clamp (7) Operating key (8) Foot screw (9) Sighting collimator (10) Eyepiece (11) Display (12) Base plate (13) Focusing knob (14) Battery (15) Horizontal tangent screw and motion clamp (16) Communication interface (17) Base locking lever

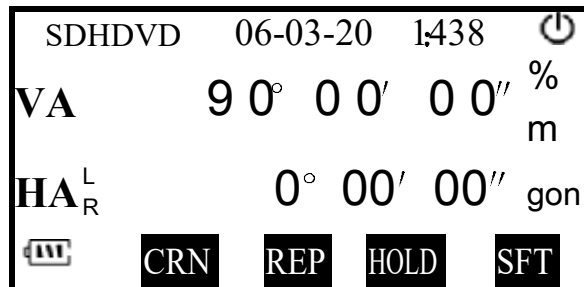

3. Display and display mark

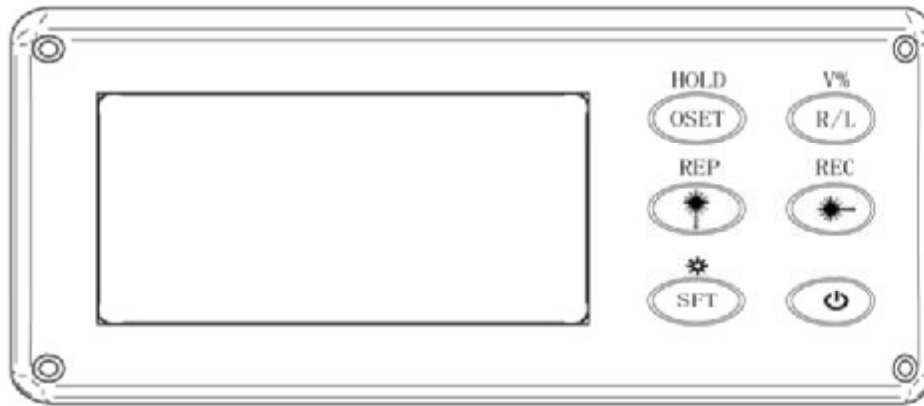

| Display | Function | Display | Function |
|-----------------|-----------------------------|----------|---------------------------|
| SD | Slope distance | HOLD | Hold the horizontal angle |
| HD | Horizontal distance | % | Percent grade |
| VD | Height difference | m | Distance unit : m |
| VA | Vertical angle | gon | Angle unit |
| HA ^L | Horizontal angle left | | Battery level |
| HA _R | Horizontal angle right | 07-03-06 | Date |
| SFT | The second function | 14: 38 | Time |
| REP | Repeat the horizontal angel | | Auto power off |
| CRN | Tilt correction | | |

4. Operating keyboard and operating key



| keys | Function 1 | Function 2 |
|---|---------------------------------------|-------------------------------------|
| OSET | Set horizontal angle 0 | Hold the horizontal angle |
|  | Laser plummet switch | Repeat horizontal angle measurement |
| SFT | Select the second function | Turn on or off illumination |
| R/L | Switch horizontal angle right or left | Percent grade of vertical angel |
|  | Laser pointer switch | Record measurement data |
|  | Power switch | |

5. Preparative before measurement

5.1 Level the instrument

Level and center the instrument correctly to insure the best performance.

① Place the tripod

First, put the tripod leg in the proper position and tighten the locking screws.

② Attaching the instrument to the tripod head

Place the instrument carefully on the tripod head, and move the instrument slowly by loosening adjusting screw. Align the plumb bob with the point on the ground. When aligned, tighten the adjusting screw.

③ Initial rough leveling the instrument with circular level

(1) Use leveling screws 1,2 to move the bubble of the circular level until the bubble is now located on a line perpendicular to a line running through the centers of the two leveling screws being adjusted.

(2) Revolve the leveling screw 3 to shift the bubble to the center of the circular.

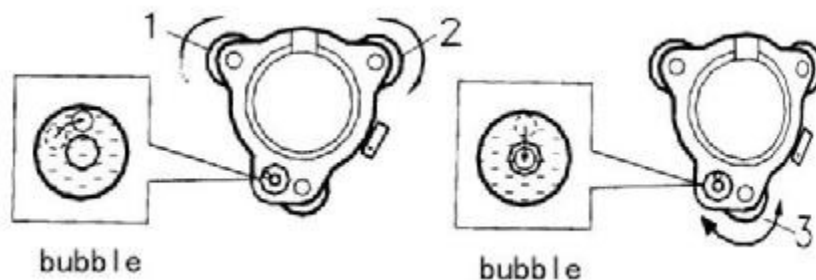

④ Further leveling the instrument with plate level

(1) Loosen horizontal motion clamp and revolve the instrument. By adjusting leveling screws 1, 2, the plate level vials is parallel to a line running through the centers of two leveling screws, and place the bubble in the center of the level vial.

(2) Next, revolve the instrument 90(100g) around its vertical axis and use the remaining screw 3 to center the level bubble once more.

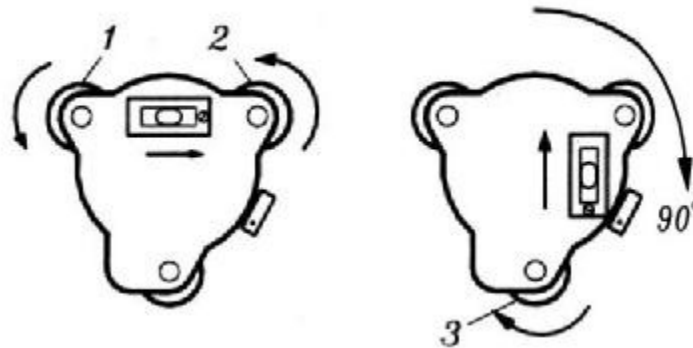

(3) Repeat the above procedure for each 90° revolution of the instrument and check whether the level bubble is correctly centered for all points.

⑤ Centering the instrument with optical plummet

Adjust the eyepiece of the optical plummet telescope to the

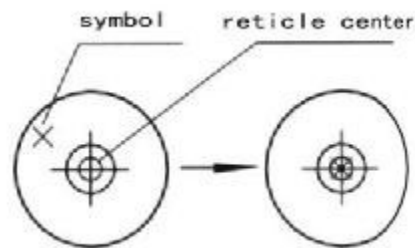

user's eyesight. Move the instrument by loosening adjusting screw. Carefully move the instrument to coincide image of the point on the ground with the center mark of the optical plummet telescope.



⑥ Centering the instrument with laser plummet

Switch on the instrument, press **【↑】** open the laser plummet, carefully move the instrument to coincide image of the point on the ground with the laser spot.





⑦ Final leveling of the instrument

Repeat procedure of ④. and check whether the level bubble is in the center of the level vial. Finally tighten adjusting screw.

5.2 Power switch on

- ① Press **【】**, all segments of the display will light on. The display shows vertical angles and horizontal angle.
- ② Press **【】** over 2 seconds, it can be power off.
 - In order to make sure instrument work continuously, pay attention to battery power display. If battery power is insufficient, replace battery. Please see 5.3. Battery power display.

5.3 Battery power display

| Mark | Meanings |
|---|---|
|  | Sufficient battery power (%90-%100). |
|  | Effective battery power (%50-%90). |
|  | Effective battery power (%10-%50). |
|  | Poor battery power (0-%10).Need to replace battery |
|  | Measurement is impossible. The power will be cut off in one minute. |

5.4 Change the batteries

For removing



- Press the release button of the battery case and hold it on.
- Pull the battery case toward you.
- Remove it out.

Installation

- Press the release button and hold the battery case toward the groove in the instrument.
- Push the case until it is fixed.

6. Angle measurement

6.1 Measuring a H_AR and vertical angle

| Operating | Display |
|---|---|
| 1. Collimate the first target (A). | |
| 2. Press 【0SET】 twice, and set horizontal angel of target A at 0° 00' 00" . | <div style="text-align: right;">07-03-06 1:438</div> VA 90° 00' 00" HA R 0° 00' 00"  |
| 3. Collimate the second target (B). the required H/V angle to target B are displayed. | <div style="text-align: right;">07-03-06 1:438</div> VA 90° 00' 00" HA R 0° 10' 00"  |

● How to collimate

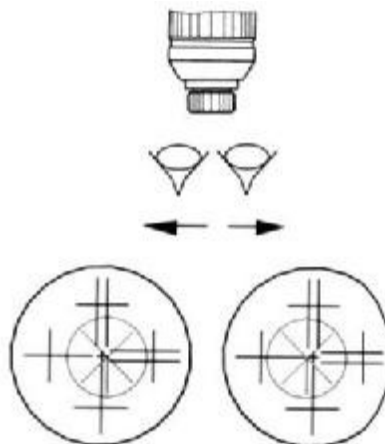

- ① Point the telescope towards the light. Turn the diopter ring and adjust the diopter so that the cross-hair is clearly observed. (Turn the ring toward you first and then backward to focus.)
- ② Observe the target with sighting collimator. Allow a certain space between the collimator and yourself, if for collimating.
- ③ Focus the target with the focusing knob.





Note

If parallax is created between the cross-hair and target when viewing vertically or horizontally while looking into the telescope, focusing is incorrect or diopter adjustment is poor. This adversely affects precision in measurement or survey. Eliminate the parallax by carefully focusing and diopter adjustment.

6.2 Switching horizontal angle HA_R /HA_L

| Operating | Display |
|---|---|
| 1. Collimate the target A. | <div style="text-align: right;">07-03-06 1:438</div> VA 90° 00' 00" HA _R 0° 10' 01"  |
| 2. Press 【 R/L 】, The mode Horizontal Angle Right(HA _R) switches to Horizontal Angle Left(HA _L) mode. | <div style="text-align: right;">07-03-06 1:438</div> VA 90° 00' 00" HA _L 359° 49' 59"  |
| 3. Measure the target in the same manner as HA _R mode. | |
| <ul style="list-style-type: none"> ● Every time 【 R/L 】 key is pressed, HA_R / HA_L mode switches. | |



6.3 Setting a horizontal angle

| Operating | Display |
|--|--|
| 1. Turn Horizontal tangent screw and set the horizontal angle required. | <div style="border: 1px solid black; padding: 5px;"> 07-03-06 1:438 VA 90° 00' 00" HA R 30° 00' 00"  </div> |
| 2. Press 【SFT】 , then press 【HOLD】 key twice and the horizontal angle is hold. | <div style="border: 1px solid black; padding: 5px;"> 07-03-06 1:438 VA 90° 00' 00" HA R 30° 00' 00"  HOLD </div> |
| 3. Collimate the target. | |
| 4. Press 【HOLD】 key again to stop holding the horizontal angle. | <div style="border: 1px solid black; padding: 5px;"> 06-03-20 1:438 VA 90° 00' 00" HA R 30° 00' 00"  </div> |

6.4 Repetition angle measurement

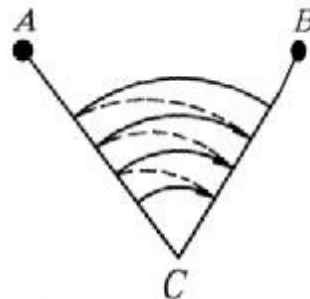

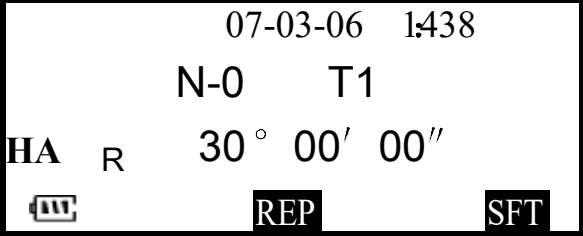
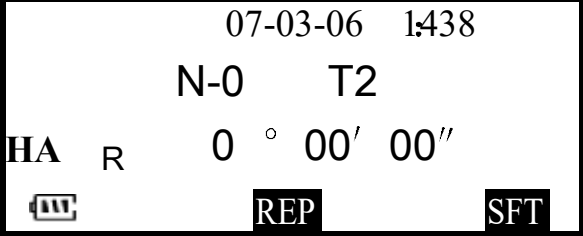
To find the horizontal angle with greater precision, perform repetition measurement.

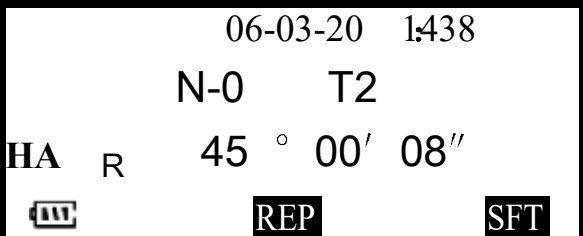
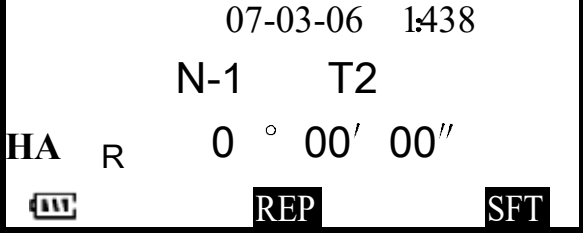

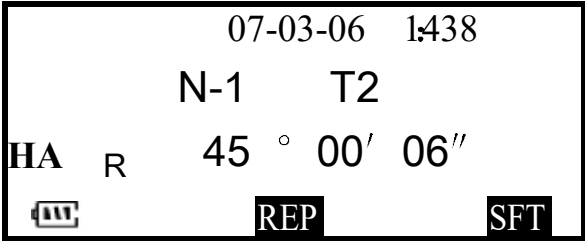
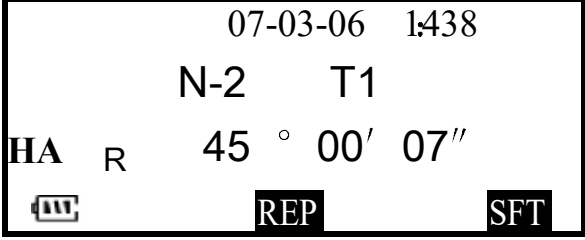
| Operating | Display |
|--|--|
| 1. Press 【SFT】 , and then press 【 (REP)】 to begin repetition angle measurement. |  |
| 2. Collimate the target A. | |
| 3. Press 【0SET】 , and set the horizontal angle of A to 0° 00' 00". |  |
| 4. Collimate the second target B using the horizontal tangent screw and motion clamp. | |
| 5. Press 【】 , and hold the horizontal angle. |  |
| 6. Re-collimate the first target A using the horizontal tangent screw and motion clamp. | |
| 7. Press 【0SET】 , and set the horizontal angle of A to 0° 00' 00". |  |

| | |
|---|--|
| <p>8. Re-collimate the second target B using the horizontal tangent screw and motion clamp.</p> |  |
| <p>9. Press 【↑】. The average of angle is shown.</p> |  |
| <p>10. Repeat 2 ~ 9 to measure the desired number of repetitions.</p> | |
| <ul style="list-style-type: none"> ● The maximum number of angle measurements that can be made is 9. ● Press 【SFT】 to exit from this mode. | |

6.5 Measuring a percent of grade (Slope measurement)

| Operating | Display |
|--|--|
| 1. Press 【SFT】 , then press 【R/L】 the display of vertical angle switches to percent grade. | <div style="border: 1px solid black; padding: 5px; text-align: center;"> 07-03-06 1:438 VA -3.108 % HA R 30 ° 00' 00"  </div> |
| 2. Press 【R/L】 again. The display turns back to normal angle measurement mode. | <div style="border: 1px solid black; padding: 5px; text-align: center;"> 06-03-20 1:438 VA 91 ° 46' 50" HA R 30 ° 00' 00"  </div> |
| Every time pressing 【R/L】 , the display mode will switches. When measured grade is exceeding $\pm 100\%$ "EEEE.EEE" is displayed. | |

7. Distance measurement

7.1 Using together with the range finder

This instrument can be used by combining with the range finder (EDM) to perform the function of Total Station. Before measuring distance, the atmospheric correction and the prism constant of the EDM should be set correctly. For more detail information, please refer to the EDM operating manual.

7.2 Join with the EDM

Join the instrument and EDM with the coupling equipment. Connect theodolite's data communication interface to EDM'S using a data cable. Adjust the adjustment screw, make sure the optical axis parallel with the EDM'S. Reference the fig.

7.3 Distance measuring

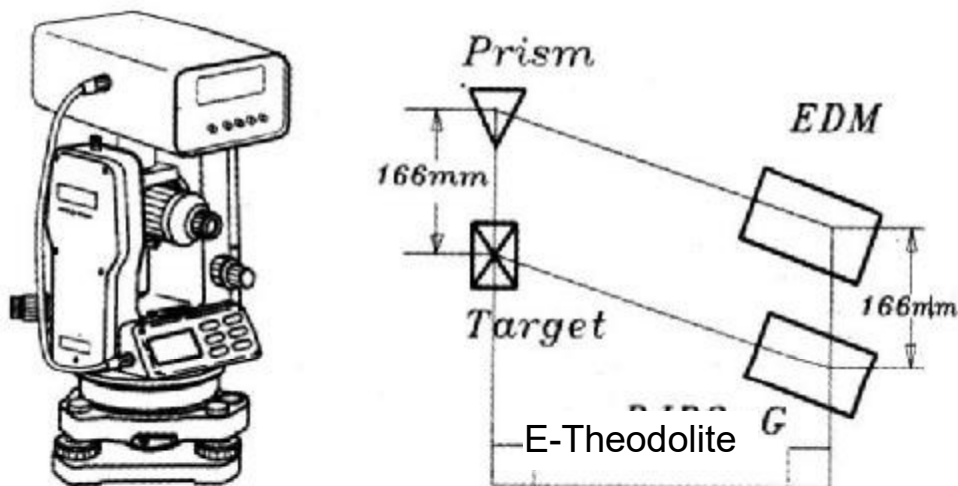

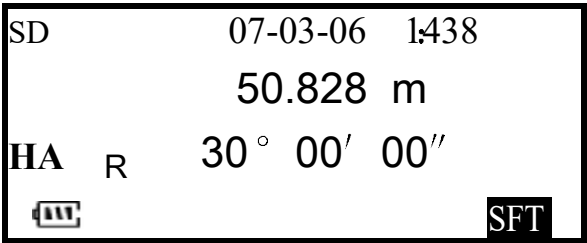
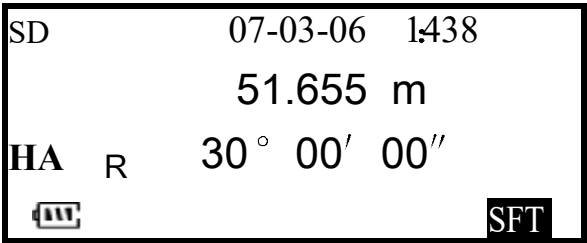
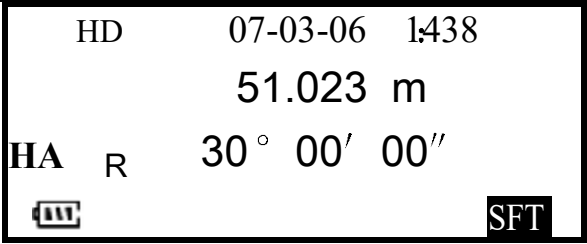
| Operating | Display |
|--|--|
| <p>1. Press 【SFT】, and then press 【↑】 to come in the distance measurement mode. If the last measured distance data is effect, it will be displayed, or “-----” will be displayed.</p> |  |
| <p>2. Collimate the target using the telescope, while Aiming the prism using the EDM.</p> | |
| <p>3. Press 【↑】. The instrument begins communication with the EDM, waiting the data from the EDM, while the title SD is blinking. If the communication success, the distance measuring result is displayed.</p> |  |
| <p>4. Press 【R / L】. SD (slope distance), HD(horizontal distance), VD (height difference)are displayed alternately,</p> |  |
| <p>5. Press 【SFT】 to come back to angle measurement mode.</p> | |

8. Recording and outputting data

This series of theodolite provides function of recording measurement data. The angle data and the distance data can be stored in the instrument's memory (up to 1000 groups) or output through communication interface. The recorded data include time information. Before recording data, the recording method should be selected. If recording data through communication interface is selected, the communication settings should be made properly. (please see "function setting")

8.1 RS-232C Communication interface

Connecting the instrument to the computer or the PDA through the cable, the measurement data can be transferred to the computer or the data collection equipment. Remember the interface is under the vertical knob.

8.2 Recording measurement data

In the different measuring mode, press **【SFT】**, and then press **【* (REC)】**, the measurement data can be outputted to the computer or the PDA (when selecting method of recording data through communication interface), or stored in the memory of the instrument (when selecting method of recording data in the memory) .

| Mode | Output (Record) |
|---------------|---|
| Angle mode | VA, HAR (vertical angel , horizontal angle) |
| Distance mode | VA, HAR SD (vertical angle , horizontal angle , slope distance) |

1----grond

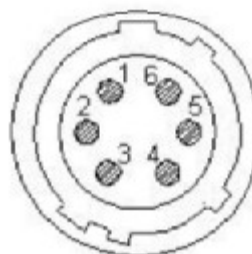

3--- -transmit (TX)

4---- receive (RX)



9. Memory mode

In the memory mode, the data recorded in the memory can be cleared or be outputted to the communication interface.

| Operating | Display |
|---|---|
| 1. Turn on while Pressing 【*】 , enter in <ul style="list-style-type: none"> ● The first line displays the effective data items in the memory. | <div style="border: 1px solid black; padding: 5px; text-align: center;"> 07-03-06 1,438 N 3 -----  </div> |
| 2. Press 【*】 , the second line will glint, and the instrument output the data to the interface. | <div style="border: 1px solid black; padding: 5px; text-align: center;"> 07-03-06 1,438 N 3 -----  </div> |
| 3. Press 【↑】 , the first line will glint, press 【↑】 again in 5 seconds, then all the data in the memory will be cleared, and after doing this, the instrument exit from the memory mode and enter the angle measurement mode. | <div style="border: 1px solid black; padding: 5px; text-align: center;"> 07-03-06 1,438 VA 91° 46' 50" HA R 30° 00' 00"  </div> |
| <ul style="list-style-type: none"> ● In the memory mode, press 【SFT】 to return to the angle measurement mode. | |

10. Function setting

10.1 Function setting

The flowing setting items can be set by user:

- ① Tilt angle compensation: *OFF, ON
- ② Vertical angle measurement mode: *U1、U2、U3。

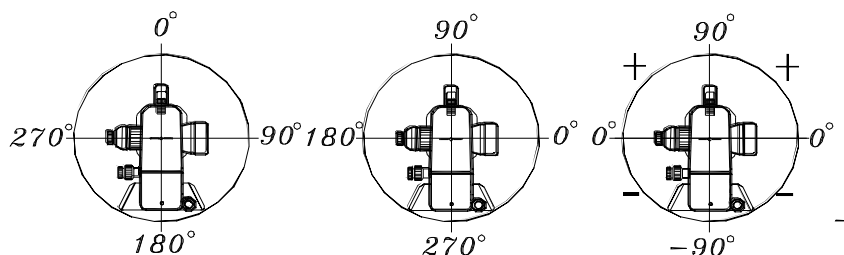

U1.Zenith angle U2.Vertical angle U3.Height angle

- ③ Automatic power off : OFF, ON (If no operation in 20minutes, turn off automatically)
- ④ Minimum angle display : *1"、5"、10"
- ⑤ Setting communication baud rate:
1200、2400、4800、*9600
- ⑥ Selecting data recording method:
*interface (OFF) ,memory (ON)
- ⑦ Collimation error correction: *OFF, ON
- ⑧ Buzzer: OFF, *ON
- ⑨ Selecting unit of angle: *dms (OFF) ,gon (ON)

Options Marked with "*" are the factory default settings.

10.2 Function setting method

In normal angle measurement mode, press the **【SFT】** key and **【R/L】** key at the same time to enter setting mode. In this mode, the keys function as following:





【0SET】: Select the item circle.

【↑】: Select the time item (month, date, year, hour, minute) .





【R/L】: Select the upwards item or the time item add 1.

【↓】: Select the downwards item or the time item minus 1.

【SFT】: Confirm the setting, exit the setting mode, return to the angle mode.

| Operating | Display |
|---|---|
| 1. Press 【SFT】 key and 【R /L】 key at the same time, come in the setting mode. | <div style="text-align: center;">07-03-06 1:438</div> <div style="text-align: center;">1. OFF</div>  |
| 2. Press 【0SET】 to select the item (①~⑦). | <div style="text-align: center;">07-03-06 1:438</div> <div style="text-align: center;">2. OFF</div>  |
| 3. Press 【R /L】 or 【↓】, change the setting of the selected item. | <div style="text-align: center;">07-03-06 1:438</div> <div style="text-align: center;">2. ON</div>  |
| 4. Setting all the items as you need. | |
| 5. Press 【SFT】 to finish setting return to the angle measurement mode. | <div style="text-align: center;">07-03-06 1:438</div> <div style="text-align: center;">VA 91° 46' 50"</div> <div style="text-align: center;">HA R 30° 00' 00"</div>  |

10.3 Time setting

| Operating | Display |
|---|---|
| 1. Press 【SFT】 key and 【R/L】 key at the same time, come in the setting mode. | <div style="border: 1px solid black; padding: 5px; text-align: center;"> 07-03-06 1438 1. OFF  </div> |
| 2. Press 【↑】 to select the item (month, data, year, hour, minute, second), the selected item will glint. | <div style="border: 1px solid black; padding: 5px; text-align: center;"> 07-03-06 1438  </div> |
| 3. Press 【R/L】 or 【* -】 , add or minus it. | <div style="border: 1px solid black; padding: 5px; text-align: center;"> 07-03-06 1438  </div> |
| 4. Press 【SFT】 to return to the angle measurement mode. | <div style="border: 1px solid black; padding: 5px; text-align: center;"> 07-03-06 1600  </div> |

11. Vertical angle 0 error and collimation error and tilt angle compensator 0 error correction

With this option, making both face angular observations, You can measure and adjust tilt compensator 0 position error. And you can measure collimation error in your instrument so that the instrument can correct subsequent single face observations. The 0 index of the vertical circle of your instrument can be reset also, and the index error that will affect the accuracy of vertical angle measurement can be corrected.

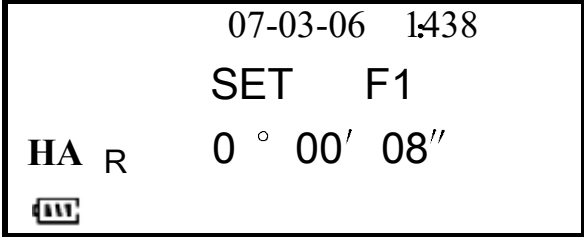
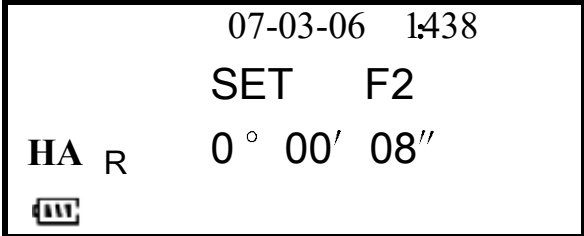
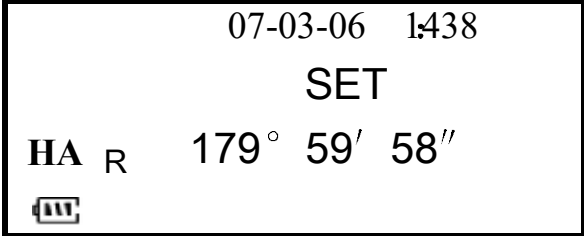
| Operating | Display |
|--|--|
| 1. Turn on while Pressing 【R/L】 , enter in , “SETUP” is shown. then the first line will display “SET F1” and glint. |  |
| 2. Level the instrument and collimate the reference target in normal telescope setting (Face 1), press 【0SET】 , the first line will glint and display “SET F2”. |  |
| 3. Turn the telescope in reverse setting (Face 2), collimate the same target, press 【0SET】 , the first line will glint and display “SET”. |  |
| 4. Press 【0SET】 to complete and return to the angle mode. | |
| ● If you want to exit at any time, you can press 【SFT】 . | |

Note: After adjustment above finished, you should check the instrument again. Collimate the same target in Face1 and Face 2, the vertical angle summation should be within $360^\circ \pm 15''$ range. If out of range, you should adjust it again or follow “13.4 Collimation of the instrument” .

12. Other function

12.1 Measuring distance

Measuring distance with cross-hair is another application of electronic theodolite. So scale station pole is needed, for example horizontal measuring staff and apparent distance staff. By viewing through the telescope, the length between upper and under stadia hairs which multiplies 100 is the distance from instrument center to station pole. (The length refers to the reading from station pole between two stadia hairs.)

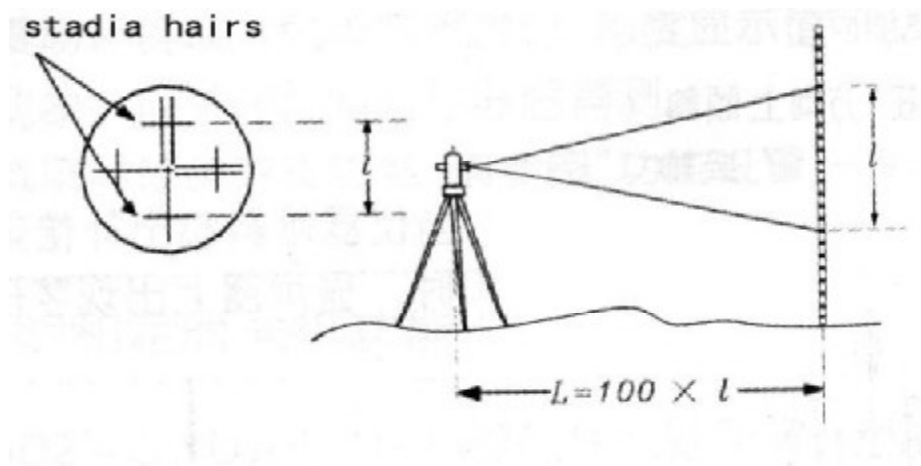

- ① First fix the station pole at the measuring point.
- ② Level instrument. By viewing through the telescope, make sure the reading “ ” between two stadia lines.
- ③ The distance from instrument plumb bob center to station staff “L” is 100 times of “l”. $L=100 \times l$

12.2 Tilt correction function

This electronic theodolite provides vertical axis incline compensator. It can compensate the incline angle automatically. When the incline sensor is switch on, the instrument can detect the vertical axis incline angle. When instrument incline over the compensation range, it display “TILT”. You should level the instrument manually.

The vertical axis is inclined in "X"

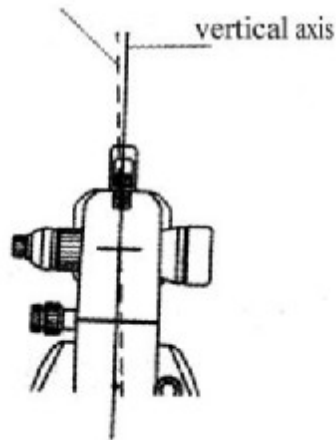

Note:

- The angle display is unstable when instrument is on an unstable stage or a windy day. You should turn off the auto tilt compensation.
- Turn on or off auto tilt compensation function, please refer to “10.funtion setting”.

12.3 Illumination and timing close

This electronic theodolite has a display and illumination setting on the reticle. When you press **【SFT】** and hold on about two seconds, the display and the illumination setting will be open or closed.

If there is no operation in 20 minutes, the power will be closed. About this function, please refer to “10.funtion setting”

13. Check and adjustment

Pointers on adjustment

- Adjust the eyepiece of the telescope properly prior to any checking operation which involves sighting through the telescope. Remember to focus properly, with parallax completely eliminated.
- Carry out the adjustment in the order listed, as the adjustments are dependent one upon another. Adjustments carried out in the wrong sequence may even nullify previous adjustments.
- Conclude adjustments by tightening the adjustment screws securely (but do not tightening them more than necessary, as you may strip the threads, twist off the screw necessary, as you may strip the threads, twist off the screw or place undue stress on the parts.)
- The attachment screws must also be tightened sufficiently upon completion of adjustments.
- Always repeat checking operations after adjustments are made in order to verify results.

13.1 Check and adjust the plate level

Check

- Place the plate level parallel to a line running through the centers of two leveling screws (e.g. A, B). Use these two screws to place the bubble in the center of the plate level vial.
- Next, revolve the instrument 180° around the vertical axis and check the bubble movement of the plate level. If the bubble has been displaced, then proceed with the following adjustment

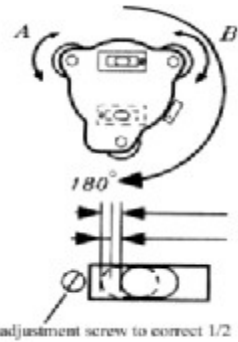

Adjustment

- Adjust the level adjustment capstan screw with the accessory adjusting pin and return the bubble towards the center of the plate level vial. However, correct only one-half of the displacement by this method.
- Correct the remaining $1/2$ amount of the bubble displacement with the leveling screws.

- c. Revolve the instrument 180° or $200g$ around the vertical axis once more and check bubble movement if the bubble is still displaced, then repeat the adjustment.

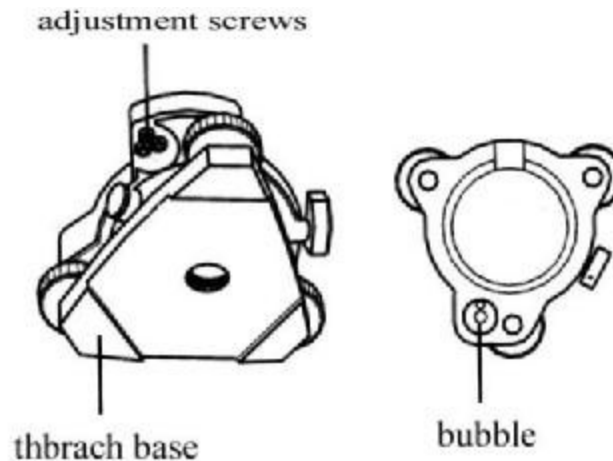

13.2 Check and adjust vertical cross-hair

Check

Carefully level the instrument with the plate level. If the bubble of the circular level is centered properly at this time, adjustment is not required. Otherwise, proceed with the following adjustment.

Adjustment

Shift the bubble to the center of the level by adjusting three capstan adjustment screws on the bottom surface of the circular level, with the accessory adjusting pin. (See diagram)

13.3 Check and adjust vertical cross-hair

Adjustment is required if the vertical cross-hair is not in a plane perpendicular to the horizontal axis of the telescope. (Since it must be possible to use any point on the hair for measuring horizontal angles.)

Check

- Set the instrument on the tripod and carefully level it.
- Sight the cross-hair on a well-defined point A on the wall at a distance of at least 50 meters. (160ft)
- Next swing the telescope and check whether the point travels along the length of the vertical cross hair.
- If the point appears to move continuously on the vertical hair (see fig.1), the vertical cross-hair lies in a plane perpendicular to the horizontal axis. (adjustment is not required.)
- However if the point appears to be displayed from the vertical cross-hair (see fig.2), adjustment is required in the reticule plate.

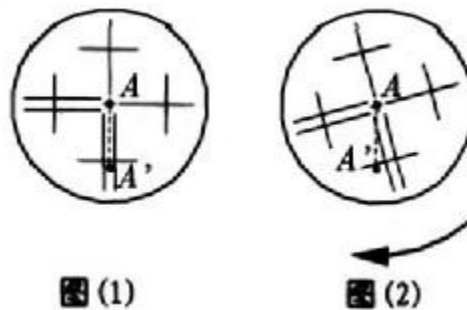

Adjustment

- Unscrew the cross-hair adjustment section cover by revolving it in the counter-clockwise direction. This will expose four eyepiece section attachment screws.
- Loosen all four attachment screws slightly with the accessory screw-driver. (while taking note of the number of the revolutions.) Make vertical cross-hair coincide with A by turning eyepiece and tighten the four attachment screws.
- Check if there is displacement in horizontal direction while point A travelling along vertical cross-hair. If not, check is concluded.

reticule retaining screws

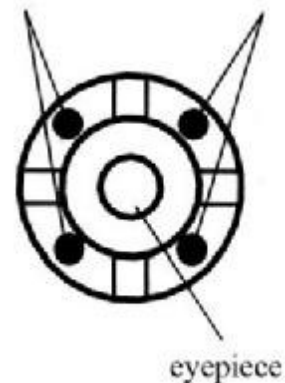

13.4 Calibration of the E-Bubble

When the instrument compensation accuracy error occurs, it needs to be adjusted. Proceed with the following steps:

Turn on, while Pressing **【R/L】** + **【*】** button, enter in.

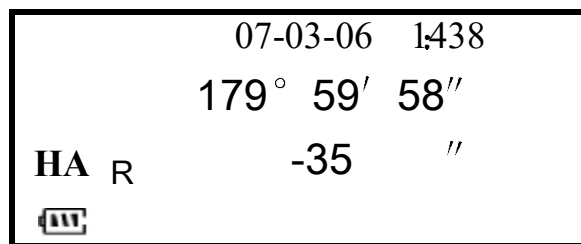

1. Make sure the vertical axis of the instrument is strict perpendicular (any rotation, plate level always centralized), Check the second line figures, if less than ± 60 , please go on the next step, if more than ± 60 , please start from the 5.step.
2. Coincide the telescope horizontal hair to collimator tube, pres **【0SET】** key.
3. Turning the theodolite base screw, make the telescope point down to 3' (the value shown on display is negative) ,Press **【0SET】** key.
4. Turning the theodolite base screw, make the telescope point up to 6' (the value shown on display is positive),Press **【0SET】** key,finish the settings.
5. When the step 1 figures more than ± 60 , you need to open the plastic cover of the battery box side, loose the E-bubble, adjust the position, to make the value less than ± 20 , and then go on the 2 ~ 4-steps.

13.5 Collimation of the instrument

Collimation is required to make the line of sight of the telescope perpendicular to the horizontal axis of the instrument.

Check

a. Set the instrument up with clear sights of about 50 to 60 meters of both sides of the instrument.

b. Sight point A at approximately 50 meter distance.



c. Loosen the vertical tangent screw only and plunge the telescope 180°



around the horizontal axis so that the telescope is pointed in the opposite direction.

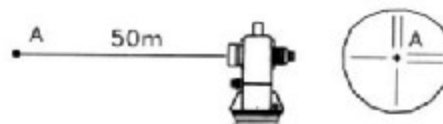

d. Sight point B, at equal distance as point A.



e. Loosen the horizontal motion clamp and tangent screw and revolve the instrument 180° or 200gon . Fix a sight on point A once more and tighten the motion clamp and screw.

f. Loosen the vertical motion clamp and tangent screw and plunge the instrument 180° or 200gon and fix a sight on point C, which should coincide with the previous point B.

g. If point B and C do not coincide, adjust in the following order:

Adjustment

- Unscrew the cross-hair adjustment section cover.
- Find point D at a point between points C. B, which should be equal to $1/4$ the distance between points B and C, and measured from point C. This is because the parent error of BC is four times of the real error since the telescope has been reversed twice during checking operation.
- Shift the vertical cross-hair line and coincide it with point D, by revolving the left and right capstan adjustment screws. Upon completing the adjustment, repeat the checking operation once more. If point B and C coincide, further adjustment is not required. Otherwise, repeat the adjustment.

Note:

- To move vertical cross-hair, first loosen the capstan adjustment screw, and then screw the capstan adjustment screws on the other side to loosened number. (Loosen screw: counter clock-wise. Tighten screw: clock-wise. But rotate screws as little as possible.)
- After concluding the above adjustment, the following adjustment is required: 6. Adjustment of vertical angle.

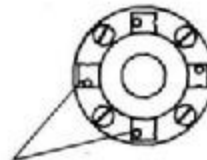
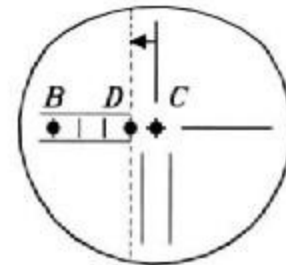

reticle adjustment screw

13.6 Check and adjust optical plummet

Adjustment is required to make the line of sight of optical plummet telescope coincide with the vertical axis (as otherwise the vertical axis will not be in the true vertical when the instrument is optically plumbed.)

Check

- Coincide the center point with the center mark of optical plummet telescope by adjusting optical plummet.
- Revolve the instrument 180 or 200g around the vertical axis

and check the center mark. If the point is properly centered in the center mark, adjustment is not required. Otherwise, adjust in the following manner:

Adjustment

- a. Unscrew the adjustment section cover of the optical plummet telescope eyepiece, by revolving it in the counter clock-wise direction and take it off. This will expose four capstan adjustment screws which should be adjusted with the accessory adjusting pin to shift the center mark to the point. However, correct only 1/2 of the displacement in this manner.
- b. Next use the leveling screws and coincide the point and center mark.

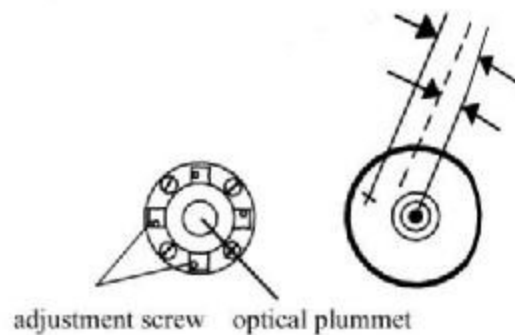

- c. Revolve the instrument 180° or $200g$ around the vertical axis, and check the center mark. If it is coincided to the point, then further adjustment is not required. Otherwise, repeat the adjustment.

Note:

To move center mark, loosen adjustment screw on one side and tighten adjustment screw on the other side according to the loosened number. (Loosen: counter clock-wise. Tighten: clock-wise. Rotate screws as little as possible.)

13.7 Check and adjust laser plummet



Open the plastic cover of the vertical plate side to reveal built-in laser plummet, as shown, there are four four-hole adjustment screws can be use to adjust the laser plummet, Adjustment procedure is the same as optical plummet.

13.8 Check and adjust laser pointer

set a goal At 50 meters, Collimate the target with the telescope cross hair, then switch on the laser pointer, check whether the laser spot coincides with the target, if not, you will need to adjust as follows:

Adjust the screw 1 and 3 to eliminate the vertical deviation. Adjust the screw 2 and the opposite tight screw to eliminate the horizontal deviation.

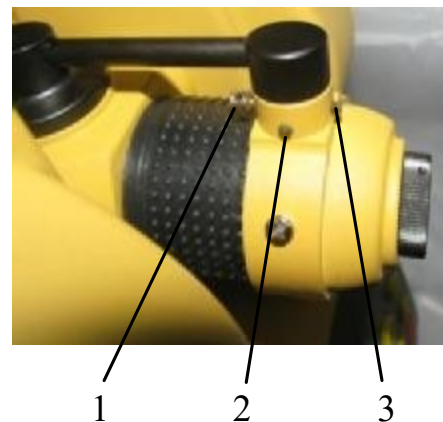

14. Tribrach

It is convenient to detach and attach instrument by loosening or tightening the locking lever.

Detachment

- a. Turn locking lever 180° in counter clock-wise direction.

- b. Lift the instrument up with one hand carrying handle and another hand holding the tribrach.

Attachment

- a. Match the instrument base with the correct groove before putting the instrument on the board.
- b. Tighten the locking lever

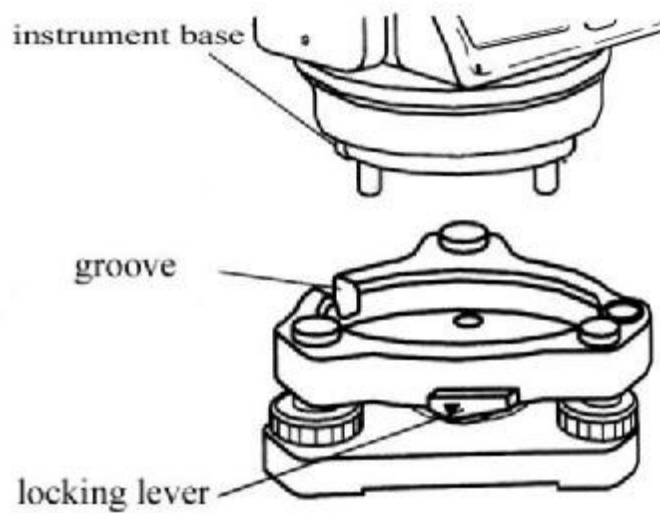

15. Error displays

| | |
|-----|---|
| E01 | Vertical angle 0 position is out of range or set with incorrect procedure. |
| E02 | Tilt angle compensator 0 position is out of range or set with incorrect procedure. |
| E03 | During measuring of the collimation error, the measured value measured is out of range. |
| E04 | There's abnormality in internal memory system. |
| E05 | Reserved for adjustment in factory. |
| E06 | There's abnormality in angle measuring system. |
| E07 | The level collimation or the telescope revolves too fast (over 4 r/s). |
| E08 | There's an error detected in angle measuring system. The instrument should be re-powered to eliminate this error. |

16. SPECIFICATIONS

| Models | | DT-2 | DT-5 |
|---------------------|-----------------------------|-----------------|------|
| Telescope | Length | 155mm | |
| | Objective aperture | 45mm | |
| | Magnification | 30X | |
| | Image | Erect | |
| | Field of view | 1° 30' | |
| | Resolving power | 2.5" | |
| | Minimum focus | 1.5m | |
| | Stadia ratio | 100 | |
| | Additive constant | 0 | |
| E-angle measurement | Measurement | Absolute coding | |
| | LCD Display | Double side | |
| | Minimum reading | 1" / 5" / 10" | |
| | Accuracy (x1) | 2" | 5" |
| | Circle Diameter | 71mm | |
| Laser Point | WaveLength | 635nm | |
| | Distance | 150m | |
| | Facula Diameter | ≤φ 5mm/100m | |
| | Precision | ≤10" | |
| Communication | EDM interface | Optional | |
| | Data output | Optional | |
| Tilt Compensator | Vertical angle compensation | Yes | |

| | | |
|-------------------|----------------------|---------------|
| | range | ±3' |
| | Minimum reading | 1"/5" |
| laser plummet | Wavelength | 650nm |
| | precision | 1mm |
| | Facular size | 1mm |
| Level sensibility | Plate level | 30" / 2mm |
| | Circular level | 8' / 2mm |
| Power | Rechargeable battery | 1500 mAh |
| | Working time | 24hours |
| | Working temperature | -20 °C~50 °C |
| Dimension | Height of instrument | 179.5mm |
| | Dimensions (DxHxM) | 160*190*324mm |
| | Weight(with battery) | 4.8kg |

* (1) according as DIN18723

17. Standard Accessories

1. Instrument Suitcase x1.
2. Charger x1.
3. Plumb Bob x1.
4. rechargeable battery x1. (Instrument comes with a Dry Battery Box set).
5. Correct Pin x2.
6. Soft Brush x1.
7. Lens Cloth x1.
8. Laser Target x1.
9. Bend Eyepiece (optional).
10. User Guide



Nivel System – *service, support*

TPI Sp. z o.o.
Bartycka 22
00-760 Warsaw
Poland

+48 22 651 03 06, +48 22 651 03 09
info@nivelsystem.com

www.nivelsystem.com