

Light Assembly Installation

1. Remove the Corner/Head/Tail light from vehicle.
2. Select location to mount lighthouse.
3. Drill 1 inch diameter hole to the light assembly.
4. Insert lighthouse into hole and secure with supplied screws.
5. Apply silicone (user-supplied) for better seal.

WARNING: DO NOT cover heat sink with silicone. It may cause damage to the product and void warranty.

NOTE: Lighthouse mounting location may vary depending on the design of the vehicle light assembly.

OPERATIONS

To +VDC (fuse @ 2A).....**RED**

To Chassis Ground.....**BLACK**

For Synchronization.....**YELLOW**

Connect **YELLOW** wires of all heads together for synchronization
(All heads must be set at the same pattern)

For Simultaneous or Alternating Flash:

1. Apply +VDC to **RED** and **YELLOW** wires simultaneously to enter Grouping mode; lighthouse will display short (single or double) flashes:
 - Single flash = Group1
 - Double flash = Group2
2. Remove **YELLOW** wire from +VDC and momentarily apply to +VDC to change Groups:
 - Heads in the same Group flash together.
 - Group1 Heads alternate with Group2 Heads.
3. Disconnect power to save and exit Grouping mode.

For Flash Patterns:

Momentarily apply +VDC to **YELLOW** wire:

- once for next pattern
- quickly three times for FP#1

NOTE: This unit may not be factory set at FP# 1.

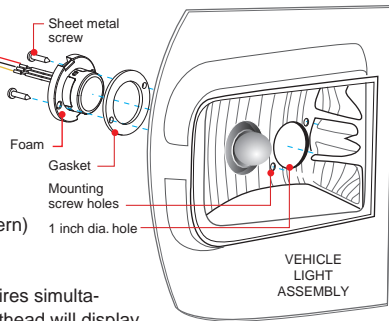

FP#	Flash Patterns	
1	Random	7 Quad
2	Steady	8 Quint
3	Single	9 Ultra
4	Mega	10 Single-Quad
5	Double	11 Single H/L
6	Triple	12 Single-Triple-Quint

Flange Mount Installation

1. Use the mounting foam to mark wire and screw holes before drilling.
2. Carefully drill marked holes accordingly.
3. Insert lighthouse wires through the mounting foam and into the wire hole.
4. Secure the lighthouse with supplied sheet metal screws.
5. Mount the snap-on flange onto the lighthouse.

NOTE: Make sure to use the foam when mounting the lighthouse.

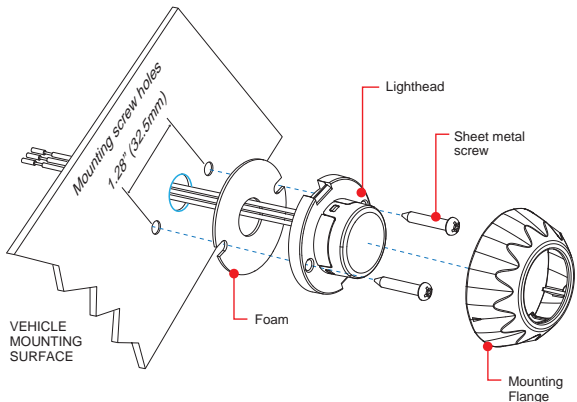

FLANGE REMOVAL

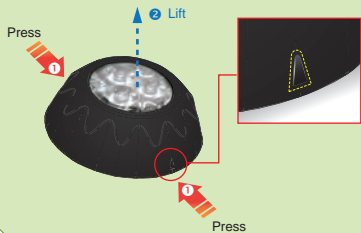

- 1 Apply pressure on both sides marked with triangle.
- 2 Lift the flange to remove.

NOTE: Avoid from multiple mount and removal of the flange to prevent loose fit.