

DIAMONDBACK *PERMANENT MOUNT*



RED: To +VDC (R65 version - fuse @8A)
(SAE version - fuse @6A)
(ECONO version - fuse @3A)

BLACK: To Chassis Ground (-)

BLUE: Flash patterns & Synchronization

- Momentarily apply +VDC to BLUE for Flash Pattern change
- Continuously apply +VDC to BLUE for Low Power
- Connect BLUE wires of all minibars together for synchronization; all units must be set at the same pattern

NOTE:

ECONO version is 12V only, and has 1 flash pattern.

WARNING:

Do not look directly into LEDs while in operation; may cause momentary blindness and/or eye damage.

FLASH PATTERNS

Momentarily apply +VDC to **BLUE**:

- Once for next pattern
- Quickly 3 times for reset to FP#1

FP#	Flash Patterns	FP#	Flash Patterns	FP#	Flash Patterns
1	Random	9	Single H/L (split)	17	Single H/L (all)
2	Single (split)	10	Single (all)	18	Steady (half)
3	Double (split)	11	Double (all)	19	Steady (all)
4	Quad (split)	12	Quad (all)	20	Single (2Hz)
5	Quint (split)	13	Quint (all)	21	Double (2Hz)
6	Mega (split)	14	Mega (all)	22	Triple (2Hz)
7	Ultra (split)	15	Ultra (all)	23	Quad (2Hz)
8	Single-Quad (split)	16	Single-Quad (all)		

Note: This unit may not be factory set at FP#1

1-BOLT MOUNT

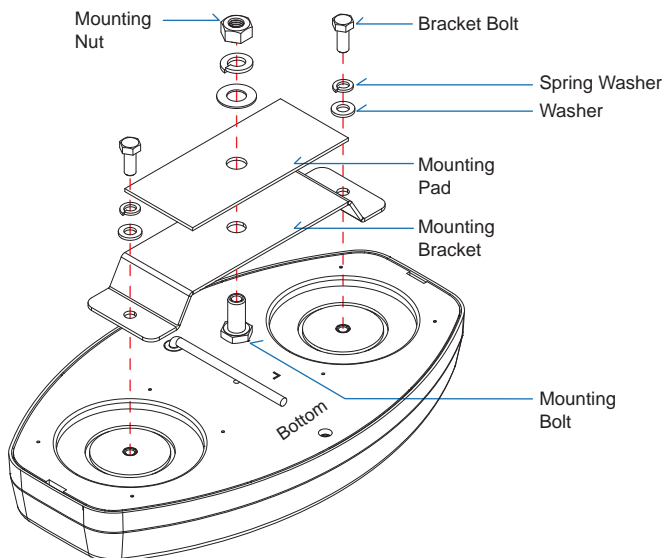

2-BOLT MOUNT

